

BOUNCE VANITY

BNC-27V (27")

CAUTION

TURN OFF THE MAIN POWER AT THE CIRCUIT BREAKER BEFORE INSTALLING THE FIXTURE IN ORDER TO PREVENT POSSIBLE SHOCK

IF YOU ARE UNFAMILIAR WITH PROPER ELECTRICAL WIRING CONNECTIONS OBTAIN THE SERVICES OF A QUALIFIED ELECTRICIAN

GENERAL

- Read all instructions carefully for safe operation and installation.
- All electrical connections must be in accordance with local and national electrical code (N.E.C) standards.
- Remove the fixture and the mounting package from the box and make sure that no parts are missing by referencing the illustrations on the installation instruction. Please contact Blackjack Lighting if any parts are missing or damaged.
- This product is suitable for damp locations.

INSTALLATION**PREPARATION**

1. Remove the fixture from its box.
2. Remove the fixture pan(11) from the back panel(10) by loosening the two screws(12).

MOUNTING

3. Pull the supply wires(2&4) and the house ground wire(6) out of the outlet box(1). Temporarily attach the back panel(10) to the outlet box(1) by carefully positioning the rear mounted driver into the junction box, taking care to push aside the supply and ground wires that might interfere. Use the two inner mounting screws(9) to temporarily support the fixture against the wall. Mark the two outer mounting hole locations (for the anchor screws(13)) on either side of the back panel(10).
4. Remove the back panel(10) from the wall. Drill the two holes for the anchor screws(13) using the appropriately sized drill bit. Insert the provided ceiling anchors(14) into the holes.

ELECTRICAL CONNECTIONS

5. Use the wire connectors(8) to connect the white supply wire(2) to the white fixture wire(3); connect the black supply wire(4) to the black fixture wire(5); and connect the house ground wire(6) to the fixture ground wire(7).

FINAL ASSEMBLY

6. Carefully re-insert the driver into the junction box. Screw the outer anchor screws(13) halfway into the ceiling anchors(14), then further attach back panel(10) to the outlet box(1) by using the two inner mounting screws(9). Afterward fully tighten the outer anchor screws(13).
7. To secure the fixture pan(11) to the back panel(10) first align the holes on the sides of the fixture pan(11) with the holes on the sides of the back panel(10). Then secure the pieces together with the two screws(12).

DIMMING

- Fixture Dimming Type: TRIAC dimmable
- For recommended dimmers see <https://www.blackjacklighting.com/dimming-information>

HARDWARE



Wire Connectors (#8)

[3 Included]

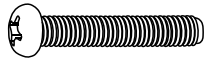

Mounting Screws (#9)

[2 Included]



Screws (#12)

[2 Included]

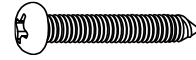

Anchor Screws (#13)

[2 Included]

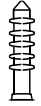

Anchor (#14)

[2 Included]

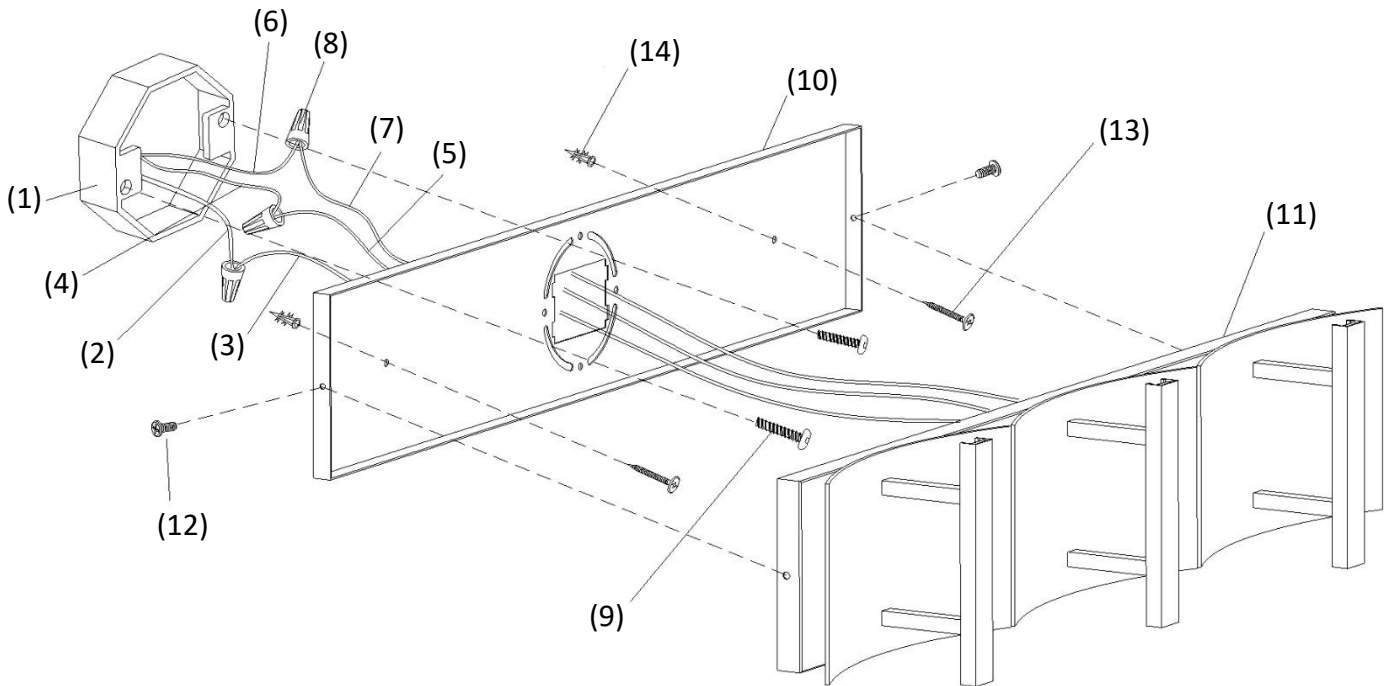

1. OUTLET BOX (by others)

2. WHITE SUPPLY WIRE

3. WHITE FIXTURE WIRE

4. BLACK SUPPLY WIRE

5. BLACK FIXTURE WIRE

6. HOUSE GROUND WIRE

7. FIXTURE GROUND WIRE

8. WIRE CONNECTORS

9. MOUNTING SCREWS

10. BACK PANEL

11. FIXTURE PAN

12. SCREWS

13. ANCHOR SCREW

14. ANCHOR